

Model

2000649

480/600V Welding Panel



FEATURES

- Prototype & Production Tested Design
- Wide range of options and accessories available
- Simple access for maintenance and operations
- Weatherproof enclosure with NEMA 3R compliance
- Safety guards for all electrical connections
- Lockable latches standard
- All aluminum enclosure construction and design
- Lockable latches standard

Panel Board

- UL and CSA standards
- Stackable design for unit storage
- Heavy duty mobile rated design
- Hard wire with aluminum gland or cam lock inlet
- Bilingual decal package ready for all markets
- All aluminum enclosure construction and design
- Bilingual decal package ready for all markets

UNIT SPECIFICATIONS

Rated Voltage	600Y/347 V AC
Rated Current	250 Amp
Branch Circuit Breaker Type	Noark
Number of Phases	3
Rated Interrupt Current	65 kA @ 480 VAC 20 kA @ 600 VAC
Connection Type	4 Wires (L1, L2, L3, GND)
Gland Type	Eco Power Equipment Standard Gland
Main Breaker SCCR Rating	65 kA @ 480 VAC 20 kA @ 600 VAC
Length [INCHES]	38.6 in
Width [INCHES]	38.6 in
Height [INCHES]	27.75
Weight [LBS]	~98 lbs pending configuration
Compliance / Approvals	SPE-1000, UL67, CSAC22.2, UL1640 Compliant Design, UL 489, CE Compliant

DIMENSIONS

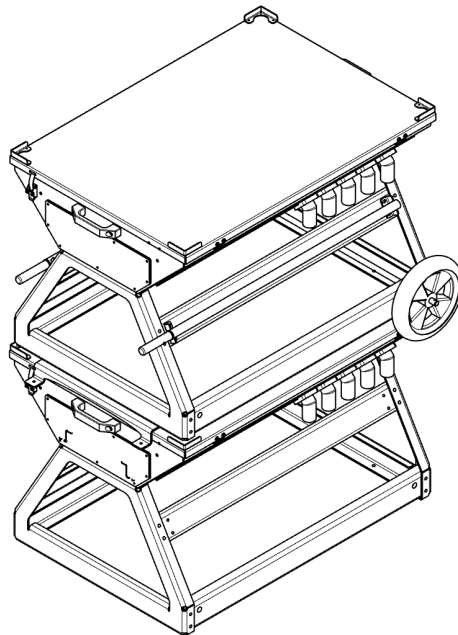
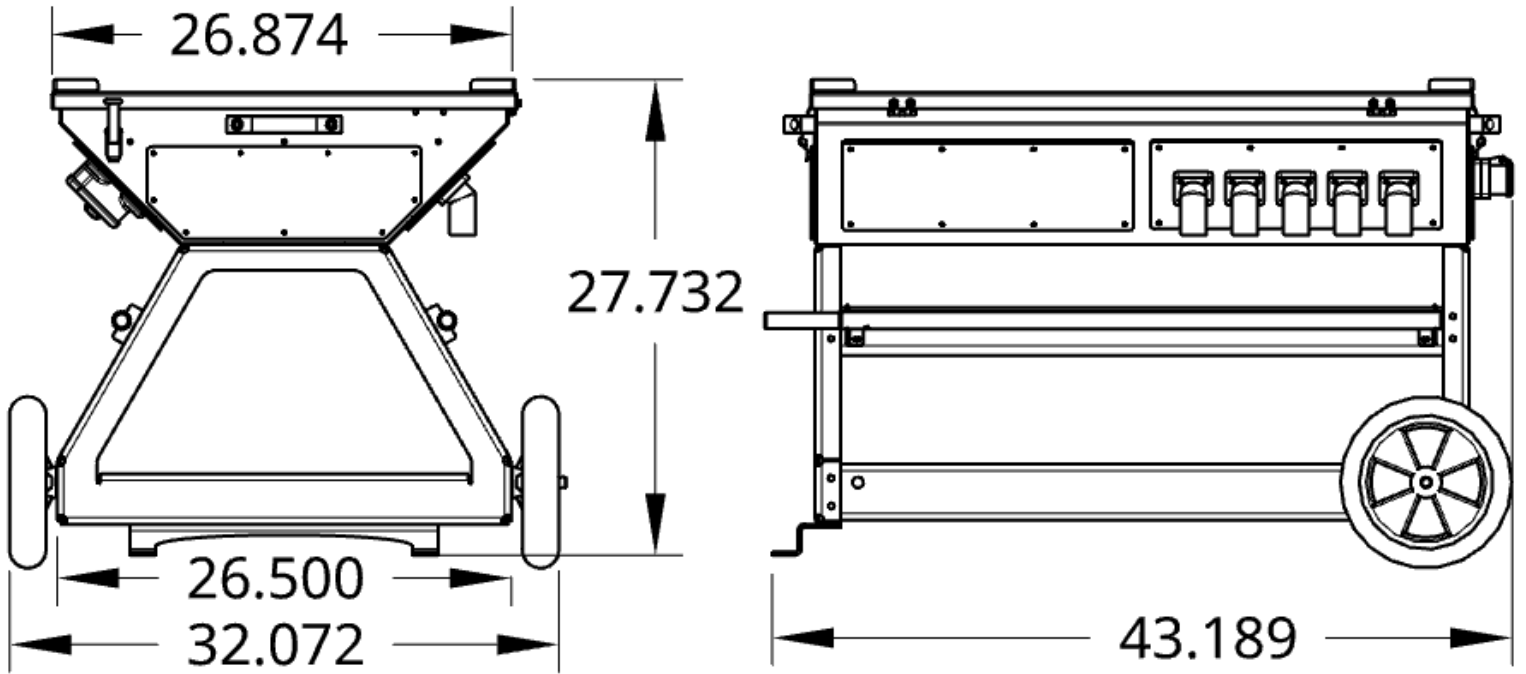

BASE WIRING DIAGRAM

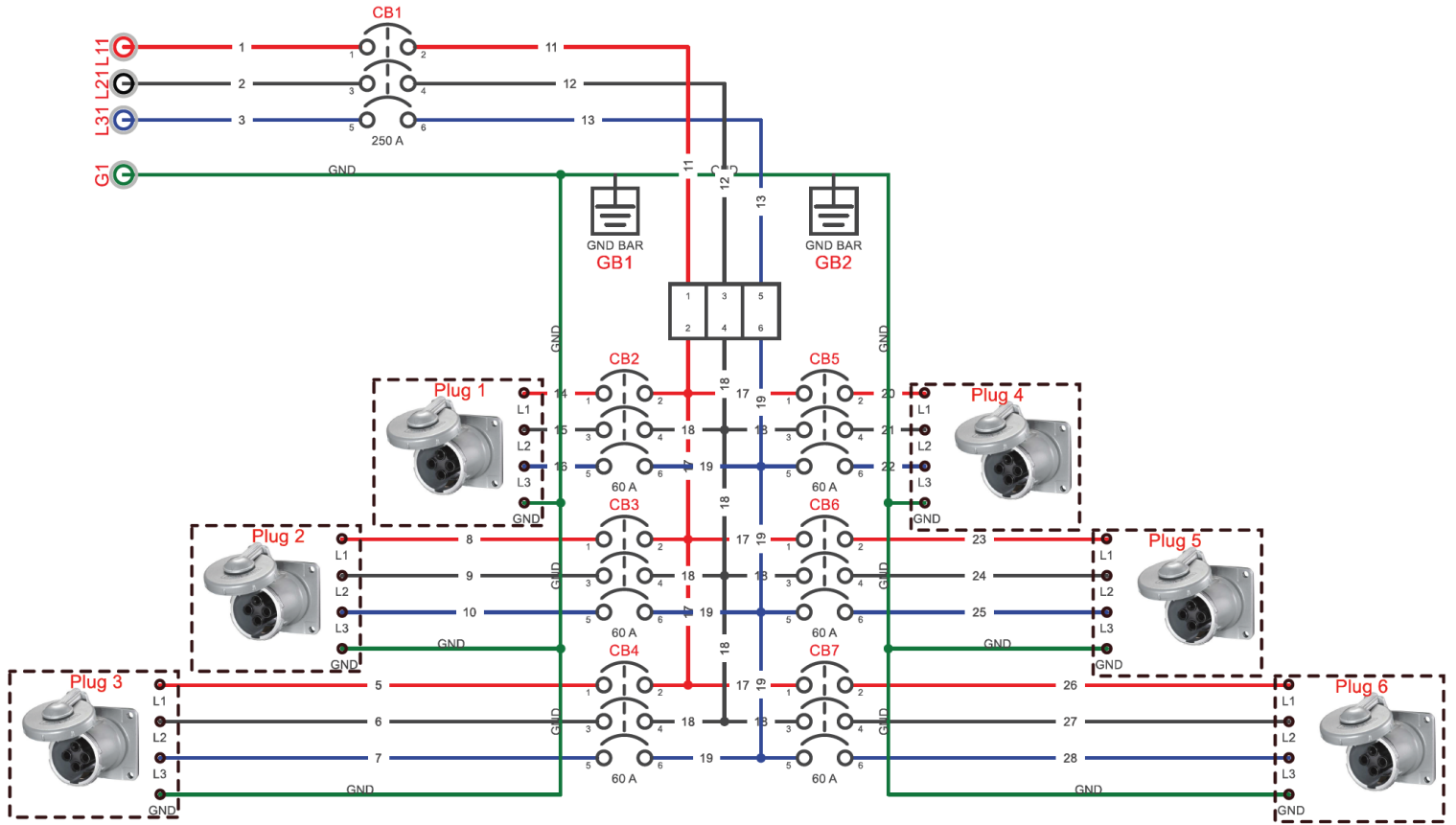

©2023 Eco Power Equipment Ltd. All rights reserved. All specifications are subject to change without notice.